

# Limit Value Switch Type TR 210

for 2 Temperature-Sensors or 0/4-20 mA, 0-10 V, 2 Limits, Analog-output

## TR 210



The limit value switch TR 210 monitors up to 2 measuring inputs for Pt 100 (RTD), Pt 1000, thermocouples, or standard-signals 0/4-20 mA, 0-10 V.

The signals are monitored for up to 4 limits. The value of one or of both inputs can be read out at an analog output.

## Application:

The TR 210 is very versatile and can thus be used in many applications. Nevertheless multiple preset programs allow an easy setting.

It can be used as a limit switch or as a controller for 2 limits (with day/night shift up to 4 limits).

As a measuring transducer it can convert signals from the temperature-sensors to standard-signals or change the scaling of standard-signals. The user can also select, if minimum or maximum of 2 signals or the difference of 2 signals is connected to the analog output.

For more applications see basic programs.

## Function

- Measuring and monitoring range  $-170...+1820\text{ }^{\circ}\text{C}$
- resolution  $0,1^{\circ}\text{C}$  (to  $999,9\text{ }^{\circ}\text{C}$ )
- Analog output (scaleable) for 1 input, min./max. of 2 inputs or difference of 2 sensors (no isolation between inputs and output)
- 2 relay outputs
- Shifting of day/night (selectable with contact at terminals Y1/Y2)
- Universal power supply AC/DC 24-240 V
- Easy setting with 3 buttons and preset programs
- Storing of min- and max-values of inputs
- Code-lock against manipulation of settings
- Terminals pluggable

## 2 Measuring-Inputs:

- Resistance-sensors Pt 100 (RTD), Pt 1000, KTY 83/84 in 2- or 3-wire-connection
- Thermocouples types B, E, J, K, L, N, R, S or T
- different sensors at both inputs possible
- Standard-signals 0/4-20 mA, 0-10 V (scaleable)

## Displays:

- 4-digit for measuring value
- 2 LEDs for state of relays
- 3 LEDs sensor/difference
- 2 LEDs day/night

## Switching-Functions:

- 2 relays (co-contacts)
- 2-4 limits
- Warmest/coldest sensor switches relay
- Programmable for every relay:
  - hysteresis (+ or - MIN- or MAX-function)
  - $-199,9...999,9\text{ s}$
  - autoreset or electronic reclosing lock
  - delay-time for switching and switching back  $0...9999\text{ s}$
  - operating- or closed current-mode
  - cyclic check of function
- Monitoring of difference in temperature
- Preset basic programs

Order-number: T 224071

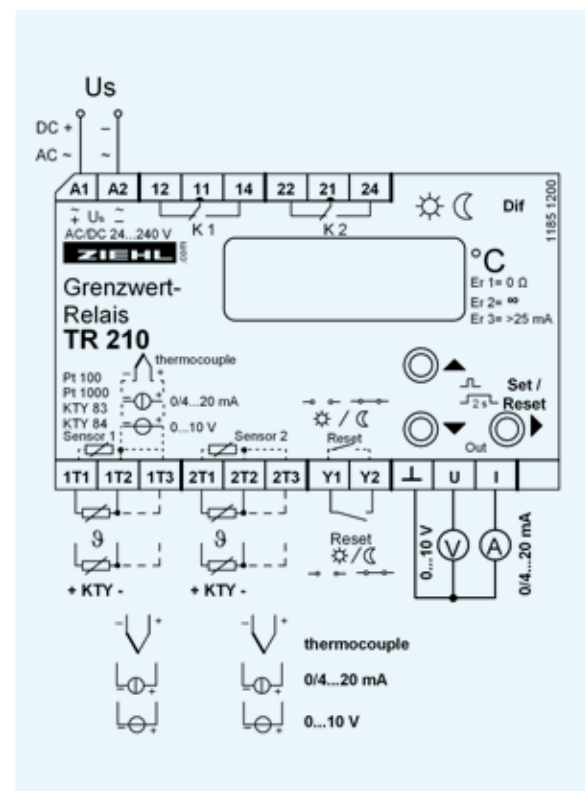

## Basic Programs

**Program 1:****1 Temperature-sensor,  
2 Limits**

Application: Monitoring of a temperature for 2 limits, e.g. over-temperature with warning and switching off or monitoring of a temperature-range (min/max).

**Program 2:****2 Temperature-Sensors,  
1 Limit for each Sensor**

Application: Monitoring of 2 temperatures for 1 limit each, e.g. over-temperature or as double electronic controller.

**Program 3:****1 Temperature-Sensor,  
2 Limits each day/night**

Application: Controlling of a temperature with first limit, different for day and night.

Monitoring of the same temperature with second limit, different for day and night.

**Program 4:****2 Temperature-Sensors,  
each 1 Limit for day/night**

Application: Monitoring or controlling of 2 temperatures for 2 limits, depending on operation mode, e.g. controlling of 2 circulation pumps (day/night) or of processes (active/stand-by).

**Program 5:****2 Temperature-Sensors for  
monitoring of differences in  
temperature, 2 Limits**

Application: Regulation or monitoring of the difference of 2 measuring-points for 2 limits, e.g. circulation pumps in solar systems.

**Program 6:****1 Standard-Signal 0/4-20 mA or 0-10 V, 2 Limits**

Display can be scaled, e.g. measuring input 4-20 mA = display 0...1200 l/h.

Application: Monitoring of signals from a measuring transducer for 2 limits, e.g. over- or under- exceeding of limits with pre-alarm and alarm or monitoring of a signal-range (min/max) and/or as measuring-transducer.

In combination with any measuring-transducers, signals like pressure, volume-flow, pH-value, ... can be monitored.

**Program 7:****2 Standard-Signals 0/4-20 mA or 0-10 V,  
1 Limit each**

Display can be scaled, e.g. measuring input 4-20 mA = display 0...1200 l/h.

Application: Monitoring of signals from 2 measuring transducers, each for 1 limit, e.g. over- or under- exceeding of a limit as double electronic controller.

**Program 8:****2 Standard-Signals 0/4-20 mA or 0-10 V for monitoring of differences of signals**

Application: Regulation or monitoring of the difference of 2 analog signals for 2 limits, e.g. levels of liquids.

**Program 9:****22 Temperature-Sensors, 2 shared Limits**

Application: Coldest (MIN) or warmest (MAX) sensor switches relay. Monitoring of 2 bearings for pre-alarm and alarm.

Application as Measuring-Transducer:

At programs **with 1 measuring-input** the output can be scaled for this input, e.g. 0...200.0 = 4-20 mA.

At programs **with 2 measuring-inputs** the output can be scaled for 1 input or min- or max- value of both inputs.

At programs **for measuring of differences** output can be scaled for 1 signal or for the difference input 2 minus input or for min- or max- value of both inputs.

Thus the TR 210 can be used as limit value switch and/or measuring-transducer simultaneously. The measured values can be forwarded to e.g. a remote display or a superior control.

## Technical Data

Rated supply voltageUs	AC/DC 24-240V, <3W, <5VA (AC 20-264 V, DC 20,4-297 V)
2 Measuring inputs	Pt 100, Pt 1000 according to EN 60 751 Thermocouples types B, E, J, K, L, N, R, S, according to EN 60 584, DIN 43 710 0/4-20 mA (22Ω), 0-10 V (13 kΩ)
Measuring-time	<2,5s to 5s, depending on speed of change of signal
Analog output	0/4-20 mA, max. 500 Ω. 0-10 V, max. 10 mA (without isolation to inputs)
Relay output	type 3, see "general technical informations" 2 x 1 co- (change-over) contact
Test conditions	see "general technical informations"
Rated ambient temperature range	-20...+60°C
Dimensions h x w x d	design V4: 90x70x58 [mm], mounting height 55 mm
Protection housing / terminals	IP 30 / IP 20 (terminals pluggable)
Weight	app. 200 g
Attachment	on 35 mm DIN-rail or with screws M 4

## Temperature-Measuring with Thermocouples

A thermocouple consists of two spot welded wires of different metals or metal alloys. When the joint (measuring point) is heated, a voltage is produced at the free ends (connection or reference junction). This effect, which is essential for the action of the thermocouple, results from the fact that a contact voltage is produced at the contact of two different metals, the value of which depends on the temperature (thermo-voltage).

The value of the contact voltage at metal junctions can be taken from the thermoelectric voltage series.

The contact value of the measuring point cannot be measured easily. When the metallic line ends form a circuit, by connecting to a measuring instrument, there are additional contact voltages at each metal junction. The total voltage in the closed circuit will equal zero as long as all junctions are on the same temperature level.

This calls for three essential requirements:

1. The open ends of the thermocouples must be led to the measuring instrument on special compensating leads in order to avoid additional contact voltages.
2. To avoid distorting contact voltages at the measuring instrument, both connecting terminals must have the same temperature (isothermal block).
3. As with the thermocouples, only the temperature difference between the measuring point and the reference junction can be measured. The temperature at the reference junction must be kept constant (by measuring with 2 thermocouples) or the measuring instrument must automatically compensate for the error incurred by the change of the ambient temperature at the reference junction (in this case at the terminal) in some electronic way.

Thermocouples cover a vast temperature range, from  $-270^{\circ}\text{C}$  to  $+2800^{\circ}\text{C}$ . Their accuracy is guaranteed to DIN 43 710 and IEC 584-1 standards which facilitates their interchangeability. Their performance curves show mainly non-linear characteristics so that a linearisation becomes necessary. Thermocouples are very small, have short response times and a stability of just a few  $^{\circ}$  Kelvin variation year by year. Their range of applications depends on the materials used for the thermocouple and the medium to be measured. Thermocouple suppliers give exact information with regard to the service life and the admissible maximum short-time temperatures.

### Which Thermocouple for which application?

#### Pt 30 Rh-Pt 6 Rh Typ B DIN EN 60 584

in mV temperatures in steps of 10  $^{\circ}\text{C}$   
reference junction 0  $^{\circ}\text{C}$

$^{\circ}\text{C}$	0	10	20	30	40	50	60	70	80	90
0	0	-0,002	-0,003	-0,002	-0	0,002	0,006	0,011	0,017	0,025
100	0,033	0,043	0,053	0,065	0,078	0,092	0,107	0,123	0,140	0,159
200	0,178	0,199	0,220	0,243	0,266	0,291	0,317	0,344	0,372	0,401
300	0,431	0,462	0,494	0,527	0,561	0,596	0,632	0,669	0,707	0,746
400	0,786	0,827	0,870	0,913	0,957	1,002	1,048	1,095	1,143	1,192
500	1,241	1,292	1,344	1,397	1,450	1,505	1,560	1,617	1,674	1,732
600	1,791	1,851	1,912	1,974	2,036	2,100	2,164	2,230	2,296	2,363
700	2,430	2,499	2,569	2,639	2,710	2,782	2,855	2,928	3,003	3,078
800	3,154	3,231	3,308	3,387	3,466	3,546	3,626	3,708	3,790	3,873
900	3,957	4,041	4,126	4,212	4,298	4,386	4,474	4,562	4,652	4,742
1000	4,833	4,924	5,016	5,109	5,202	5,297	5,391	5,487	5,583	5,680
1100	5,777	5,875	5,973	6,073	6,172	6,273	6,374	6,475	6,577	6,680
1200	6,783	6,887	6,991	7,096	7,202	7,308	7,414	7,521	7,628	7,736
1300	7,845	7,953	8,063	8,172	8,283	8,393	8,504	8,616	8,727	8,839
1400	8,953	9,065	9,178	9,291	9,405	9,519	9,634	9,748	9,863	9,979
1500	10,094	10,210	10,325	10,441	10,558	10,674	10,790	10,907	11,024	11,141
1600	11,257	11,374	11,491	11,608	11,725	11,842	11,959	12,076	12,193	12,310
1700	12,426	12,543	12,659	12,776	12,892	13,008	13,124	13,239	13,354	13,470

#### Pt 15 Rh-Pt Typ R DIN EN 60 584

in mV temperatures in steps of 10  $^{\circ}\text{C}$   
reference junction 0  $^{\circ}\text{C}$

$^{\circ}\text{C}$	0	10	20	30	40	50	60	70	80	90
0	0	0,054	0,111	0,171	0,232	0,296	0,363	0,431	0,501	0,573
100	0,647	0,723	0,800	0,879	0,959	1,041	1,124	1,208	1,294	1,380
200	1,468	1,557	1,647	1,738	1,830	1,923	2,017	2,111	2,207	2,303
300	2,400	2,498	2,596	2,695	2,795	2,896	2,997	3,099	3,201	3,304
400	3,407	3,511	3,616	3,721	3,826	3,933	4,039	4,146	4,254	4,362
500	4,471	4,580	4,689	4,799	4,910	5,021	5,132	5,244	5,356	5,469
600	5,582	5,696	5,810	5,925	6,040	6,155	6,272	6,388	6,505	6,623
700	6,741	6,860	6,979	7,098	7,218	7,339	7,460	7,582	7,703	7,826
800	7,949	8,072	8,196	8,320	8,445	8,570	8,696	8,822	8,949	9,076
900	9,203	9,331	9,460	9,589	9,718	9,848	9,978	10,109	10,240	10,371
1000	10,503	10,636	10,768	10,902	11,035	11,170	11,304	11,439	11,574	11,710
1100	11,846	11,983	12,119	12,257	12,394	12,532	2,669	12,808	12,946	13,085
1200	13,224	13,363	13,502	13,642	13,782	13,922	14,062	14,202	14,343	14,483
1300	14,624	14,765	14,906	15,047	15,188	15,329	15,470	15,611	15,752	15,893
1400	16,035	16,176	16,317	16,458	16,599	16,741	16,882	17,022	17,163	17,304
1500	17,445	17,585	17,726	17,866	18,006	18,146	18,286	18,425	18,564	18,703
1600	18,842	18,981	19,119	19,257	19,395	19,533	19,670	19,807	19,944	20,080

**Pt 10 Rh-Pt Typ S**  
DIN EN 60 584

in mV temperatures in steps of 10 °C  
reference junction 0 °C

°C	0	10	20	30	40	50	60	70	80	90
0	0	0,055	0,113	0,173	1,234	0,299	0,365	0,432	0,502	0,573
100	0,645	0,719	0,795	0,872	0,950	1,029	1,109	1,190	1,273	1,356
200	1,440	1,525	1,611	1,698	1,785	1,873	1,962	2,051	2,141	2,232
300	2,323	2,414	2,506	2,599	2,692	2,786	2,880	2,974	3,069	3,164
400	3,260	3,356	3,452	3,549	3,645	3,743	3,840	3,938	4,036	4,135
500	4,234	4,333	4,432	4,532	4,632	4,732	4,832	4,933	5,034	5,136
600	5,237	5,339	5,442	5,544	5,648	5,751	5,855	5,960	6,064	6,169
700	6,274	6,380	6,486	6,592	6,699	6,805	6,913	7,020	7,128	7,236
800	7,345	7,454	7,563	7,672	7,782	7,892	8,003	8,114	8,225	8,336
900	8,448	8,560	8,673	8,786	8,899	9,012	9,126	9,240	9,355	9,470
1000	9,585	9,700	9,816	9,932	10,048	10,165	10,282	10,400	10,517	10,635
1100	10,754	10,872	10,991	11,110	11,229	11,348	11,467	11,587	11,707	11,827
1200	11,947	12,067	12,188	12,308	12,429	12,550	12,671	12,792	12,913	13,034
1300	13,155	13,276	13,397	13,519	13,640	13,761	13,883	14,004	14,125	14,247
1400	14,368	14,489	14,610	14,731	14,852	14,973	15,094	15,215	15,336	15,456
1500	15,576	15,697	15,817	15,937	16,057	16,176	16,296	16,415	16,534	16,653
1600	16,771	16,890	17,008	17,125	17,243	17,360	17,477	17,594	17,711	17,826

**Cu-CuNi, Typ T**  
DIN EN 60 584

in mV temperatures in steps of 10 °C  
reference junction 0 °C

°C	0	-10	-20	-30	-40	-50	-60	-70	-80	-90
-200	-5,603	-	-	-	-	-	-	-	-	-
-100	-3,378	-3,656	-3,923	-4,177	-4,419	-4,648	-4,865	-5,069	-5,261	-5,439
0	0	-0,383	-0,757	-1,121	-1,1475	-1,819	-2,152	-2,475	-2,788	-3,089
°C	0	10	20	30	40	50	60	70	80	90
0	0	0,391	0,789	1,196	1,611	2,035	2,467	2,908	3,357	3,813
100	4,277	4,749	5,227	5,712	6,204	6,702	7,207	7,718	8,235	8,757
200	9,286	9,5820	10,360	10,905	11,456	12,011	12,572	13,137	13,707	14,281
300	14,860	15,443	16,030	16,621	17,217	17,816	18,420	19,027	19,638	20,252

**Fe-CuNi, Typ J**  
DIN EN 60 584

in mV temperatures in steps of 10 °C  
reference junction 0 °C

°C	0	-10	-20	-30	-40	-50	-60	-70	-80	-90
-200	-7,890	-	-	-	-	-	-	-	-	-
-100	-4,632	-5,036	-5,426	-5,801	-6,159	-6,499	-6,821	-7,122	-7,402	-7,659
0	0	-0,501	-0,995	-1,481	-1,960	-2,431	-2,892	-3,344	-3,785	-4,215
°C	0	10	20	30	40	50	60	70	80	90
0	0	0,507	1,019	1,536	2,058	2,585	3,115	3,649	4,186	4,725
100	5,268	5,812	6,359	6,907	7,457	8,008	8,560	9,113	9,667	10,222
200	10,777	11,332	11,887	12,442	12,998	13,553	14,108	14,663	15,217	15,771
300	16,325	16,879	17,432	17,984	18,537	19,089	19,640	20,192	20,743	21,295
400	21,846	22,397	22,949	23,501	24,054	24,607	25,161	25,716	26,272	26,829
500	27,388	27,949	28,511	29,075	29,642	30,210	30,782	31,356	31,933	32,513
600	33,096	33,683	34,273	34,867	35,464	36,066	36,671	37,280	37,893	38,510
700	39,130	39,754	40,382	41,013	41,647	42,283	42,922	43,563	44,207	44,852

**Fe-CuNi, Typ L**  
DIN 43 710

in mV temperatures in steps of 10 °C  
reference junction 0 °C

°C	0	-10	-20	-30	-40	-50	-60	-70	-80	-90
-200	-8,15	-	-	-	-	-	-	-	-	-
-100	-4,75	-5,15	-5,53	-5,90	-6,26	-6,60	-6,93	-7,25	-7,56	-7,86
0	0	-0,51	-1,02	-1,53	-2,03	-2,51	-2,98	-3,44	-3,89	-4,33
°C	0	10	20	30	40	50	60	70	80	90
0	0	0,52	1,05	1,58	2,11	2,65	3,19	3,73	4,27	4,82
100	5,37	5,92	6,47	7,03	7,59	8,15	8,71	9,27	9,83	10,39
200	10,95	11,51	12,07	12,63	13,19	13,75	14,31	14,88	15,44	16,00
300	16,56	17,12	17,68	18,24	18,80	19,36	19,92	20,48	21,04	21,60
400	22,16	22,72	23,29	23,86	24,43	25,00	25,57	26,14	26,71	27,28
500	27,85	28,43	29,01	29,59	30,17	30,75	31,33	31,91	32,49	33,08
600	33,67	34,26	34,85	35,44	36,04	36,64	37,25	37,85	38,47	39,09
700	39,72	40,35	40,98	41,62	42,27	42,92	43,57	44,23	44,89	45,55
800	46,22	46,89	47,57	48,25	48,94	49,63	50,32	51,02	51,72	52,43

**NiCr-CuNi, Typ E**  
DIN EN 60 584

in mV temperatures in steps of 10 °C  
reference junction 0 °C

°C	0	-10	-20	-30	-40	-50	-60	-70	-80	-90
-200	-8,824	-9,063	-9,274	-9,455	-9,604	-9,719	-9,797	-9,835	-	-
-100	-5,237	-5,680	-6,107	-6,516	-6,907	-7,279	-7,631	-7,963	-8,273	-8,561
0	0	-0,581	-1,151	-1,709	-2,254	-2,787	-3,306	-3,811	-4,301	-4,771
°C	0	10	20	30	40	50	60	70	80	90
0	0	0,591	1,192	1,801	2,419	3,047	3,683	4,329	4,983	5,646
100	6,317	6,996	7,683	8,377	9,078	9,787	10,501	11,222	11,949	12,681
200	13,419	14,161	14,909	15,661	16,417	17,178	17,942	18,710	19,481	20,256
300	21,033	21,814	22,597	23,383	24,171	24,961	25,754	26,549	27,345	28,143
400	28,943	29,744	30,546	31,350	32,155	32,960	33,767	34,574	35,382	36,190
500	36,999	37,808	38,617	39,426	40,236	41,045	41,853	42,662	43,470	44,278
600	45,085	45,891	46,697	47,502	48,306	49,109	49,911	50,713	51,513	52,312
700	53,110	53,907	54,703	55,498	56,291	57,083	57,873	58,663	59,451	60,237
800	61,022	61,806	62,588	63,368	64,147	64,924	65,700	66,473	67,245	68,015
900	68,783	69,549	70,313	71,075	71,835	72,593	73,350	74,104	74,857	75,608

**NiCr-Ni, Typ K**  
DIN EN 60 584

in mV temperatures in steps of 10 °C  
reference junction 0 °C

°C	0	-10	-20	-30	-40	-50	-60	-70	-80	-90
-200	-5,891	-	-	-	-	-	-	-	-	-
-100	-3,554	-3,852	-4,138	-4,411	-4,669	-4,913	-5,141	-5,354	-5,550	-5,730
0	0	-0,392	-0,778	-1,156	-1,527	-1,889	-2,243	-2,587	-2,920	-3,243
°C	0	10	20	30	40	50	60	70	80	90
0	0	0,397	0,798	1,203	1,612	2,023	2,436	2,851	3,267	3,682
100	4,096	4,509	4,920	5,328	5,735	6,138	6,540	6,941	7,340	7,739
200	8,138	8,539	8,940	9,343	9,747	10,153	10,561	10,971	11,382	11,795
300	12,209	12,624	13,040	13,457	13,874	14,293	14,713	15,133	15,554	15,975
400	16,397	16,820	17,243	17,667	18,091	18,516	18,941	19,366	19,792	20,218
500	20,644	21,071	21,497	21,924	22,350	22,776	23,203	23,629	24,055	24,480
600	24,905	25,330	25,755	26,179	26,602	27,025	27,447	27,869	28,289	28,710
700	29,129	29,548	29,965	30,382	30,798	31,213	31,628	32,041	32,453	32,865
800	33,075	33,685	34,093	34,501	34,908	35,313	35,718	36,121	36,524	36,925
900	37,326	37,725	38,124	38,522	38,918	39,314	39,708	40,101	40,494	40,885
1000	41,276	41,665	42,053	42,440	42,826	43,211	43,595	43,978	44,359	44,740
1100	45,119	45,497	45,873	46,249	46,623	46,995	47,367	47,737	48,105	48,473
1200	48,838	49,202	49,565	49,926	50,286	50,644	51,000	51,355	51,708	52,060
1300	52,410	52,759	53,106	53,451	53,795	54,138	54,479	54,819	-	-